

CONCRETE GRADE C40
FOUNDATIONS TO BE FLAT AND LEVEL THROUGHOUT ENTIRE LENGTH.

ISSUE	REVISION	SIG.	DATE
C	LEADING A FRAME REMOVED	M.J	16/6/09
B	REDRAWN	M.J	13/8/08
A	NEW	M.J	27/3/08

Drawn	Traced	Checked	Approved	Date
M.J		...		3/08

ABC
Avon Barrier Company Ltd.
Nova House
195 South Liberty Lane
Ashton Vale Trading Estate
Bristol BS3 2UJ
Tel: (44) (0117) 953 5252
Fax: (44) (0117) 953 5373
E-mail: MECHANICAL@AVON-BARRIER.CO.UK

Drawing Title
SG1500CR
CRASH
GROUND TRACK
GATE
FOUNDATIONS

3rd ANGLE PROJECTION
COMPUTER GENERATED
DO NOT ALTER BY HAND

IF IN DOUBT ASK

Material	Finish	Scale	Sht.	of	Rev.
		NTS	1	1	C

Drawing No.
SG1500CR_101

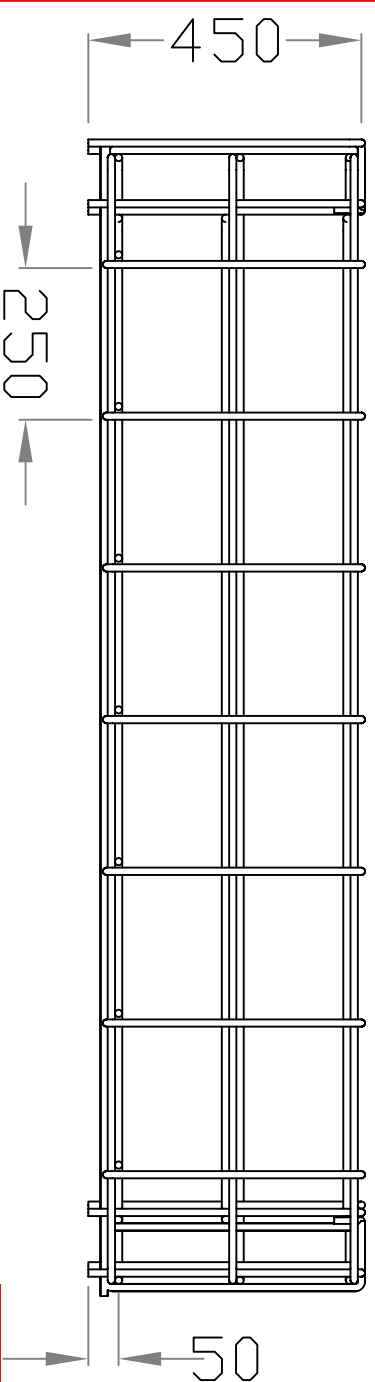
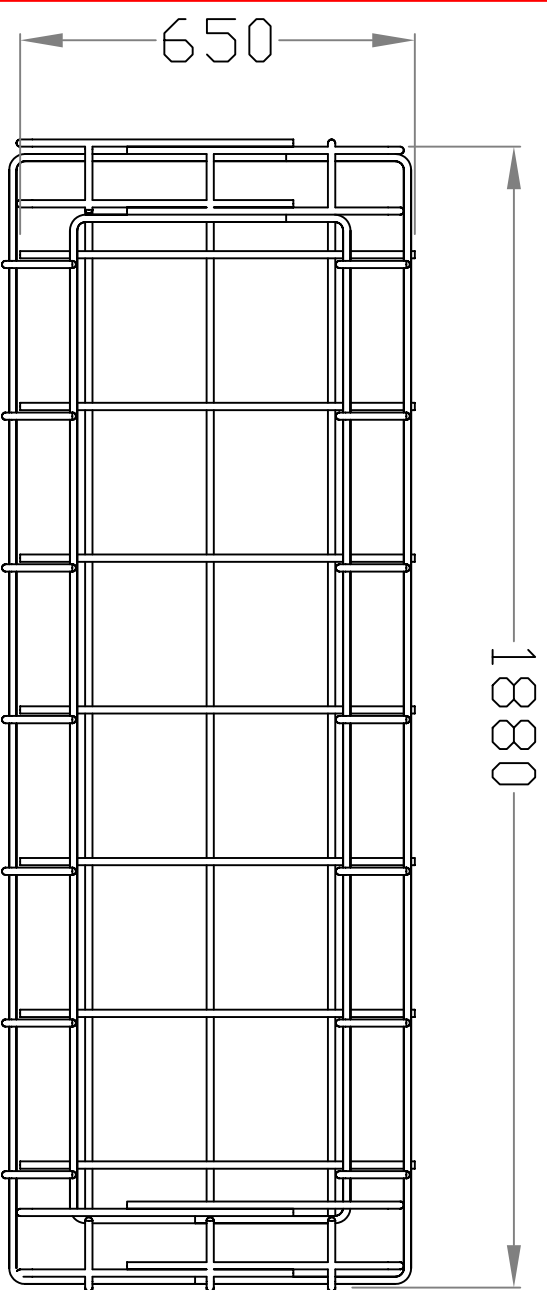
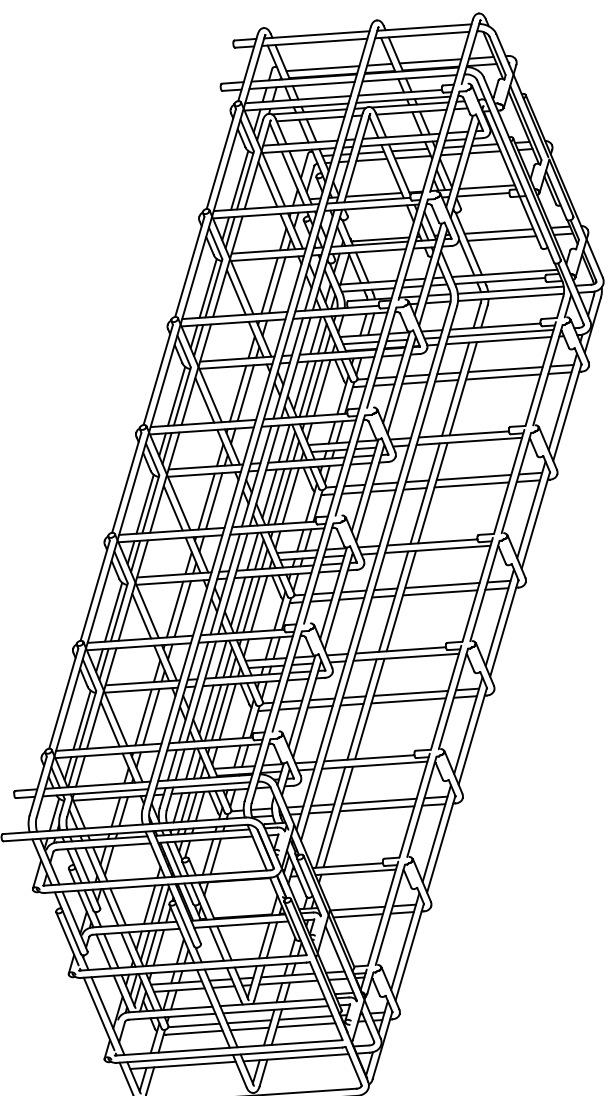

SG1500CR_103_REBAR SCHEDULE
 AVAILIABLE ON REQUEST



Avon Barrier Company Ltd.
 Nova House
 195 South Liberty Lane
 Ashton Vale Trading Estate
 Bristol BS3 2UJ
 Tel: (44) (0117) 953 5252
 Fax: (44) (0117) 953 5373
 E-mail: MECHANICAL@AVON-BARRIER.CO.UK

ISSUE	REVISION	SIG.	DATE
B	REDRAWN	...	18/8/08
A	NEW	M.J	27/3/08

Drawing Title			
CRASH GATE			
REBAR			
SCHEDULES			
(4 CAGES)			
Drawn	Traced	Checked	Approved
M.J
Drawing No.			Date
SG1500CR_102			3/08

3rd ANGLE PROJECTION	Tolerances	Used on
	±2	NONE
COMPUTER GENERATED DO NOT ALTER BY HAND	Material	Finish
	T12	NONE

IF IN DOUBT ASK

STAGE 1
EXCAVATE REF. FOUNDATION DETAIL.
COMPACT AND LEVEL BASE.

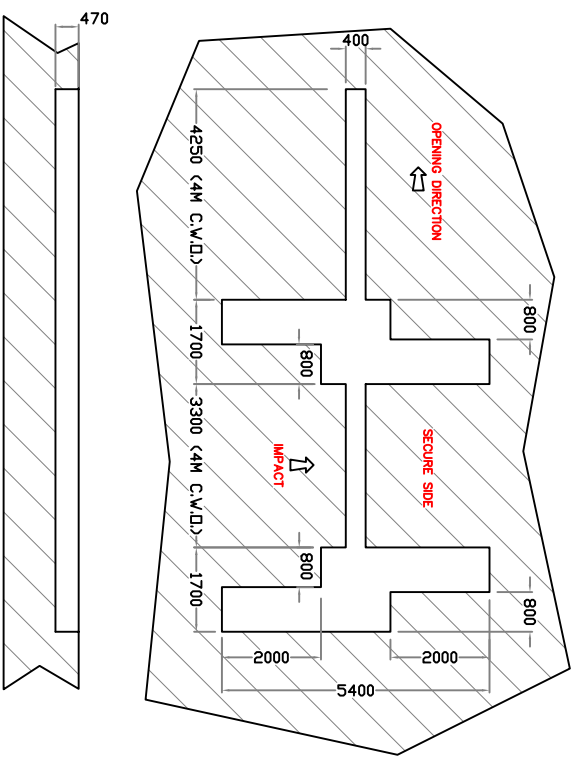

STAGE 2
PLACE REBAR CAGE INTO POSITION.

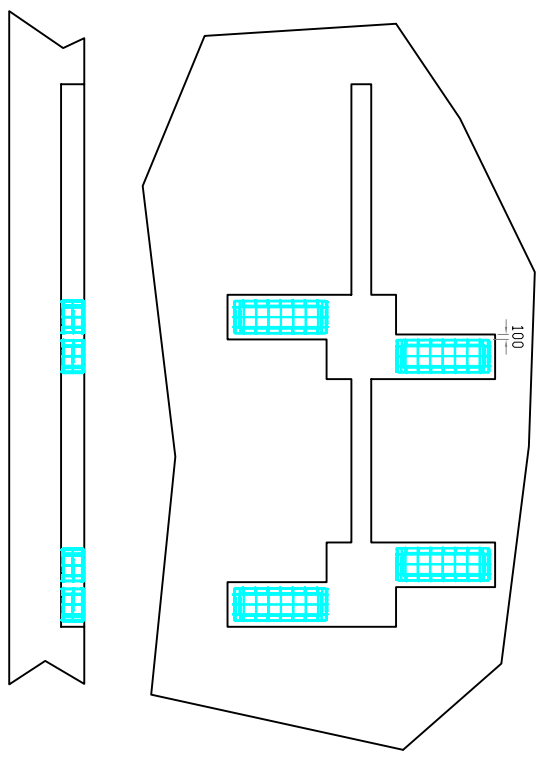

STAGE 3
FIRST POUR.
ENSURE FIRST POUR IS AT THE CORRECT DEPTH FROM FINISHED FLOOR LEVEL. TAMP TO REMOVE AIR BUBBLES. TROWEL TO A FLAT AND LEVEL FINISH TO SUIT CAMBER OF ROAD.

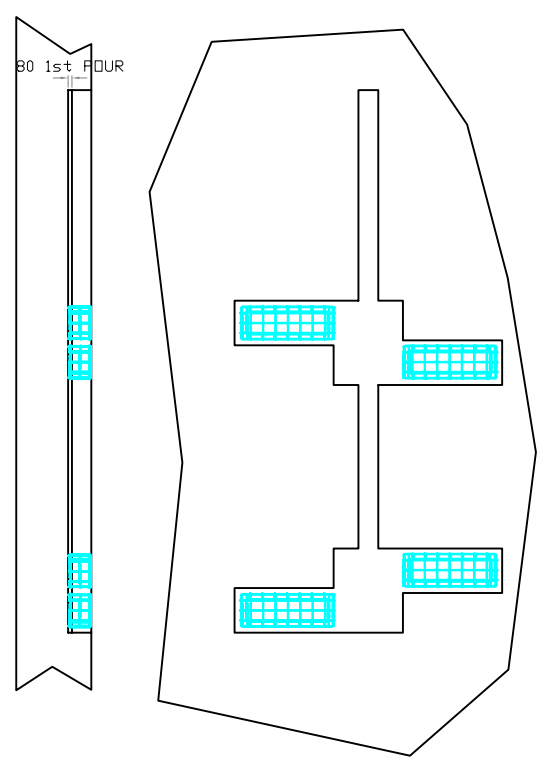

STAGE 4
MARK A CLEARLY DEFINED END-TO-END CENTRELINE THROUGH MIDPOINT OF GATE.
ORIENTATE GATE CATCHER A FRAMES.
ENSURE THE CATCHER A FRAMES ARE SITTING FLAT AND LEVEL AND PARALLEL TO THE ROAD.

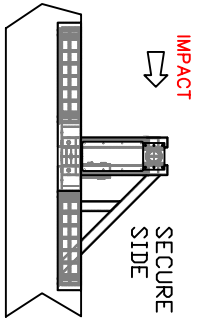
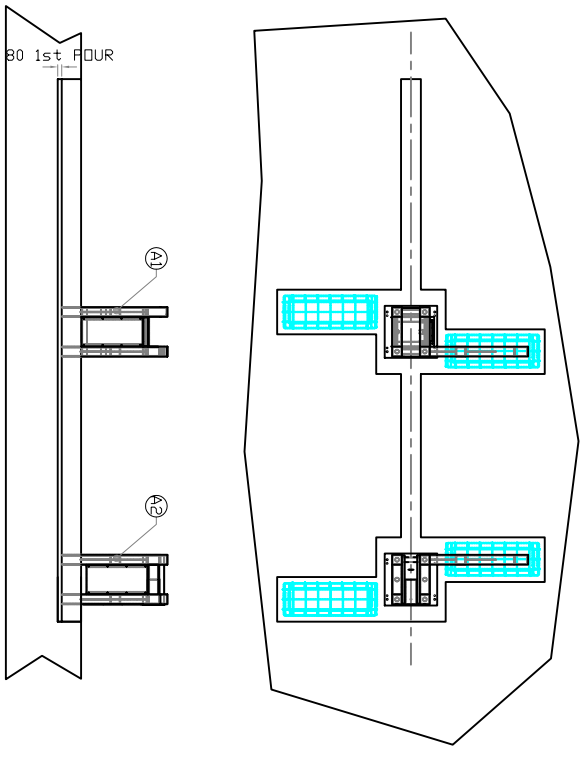

STAGE 5
BRING DUCTS INTO POSITION.
Ø50 PHOTOCELL DUCT, BETWEEN PHOTOCELL POSTS.
Ø100 POWER, Ø50 CONTROL TO MOTOR.
TRIM REBAR TO SUIT RSJ TRACK.
LEVEL AND BOLT ON RSJ TRACK.

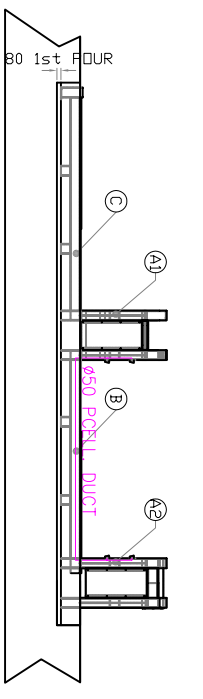
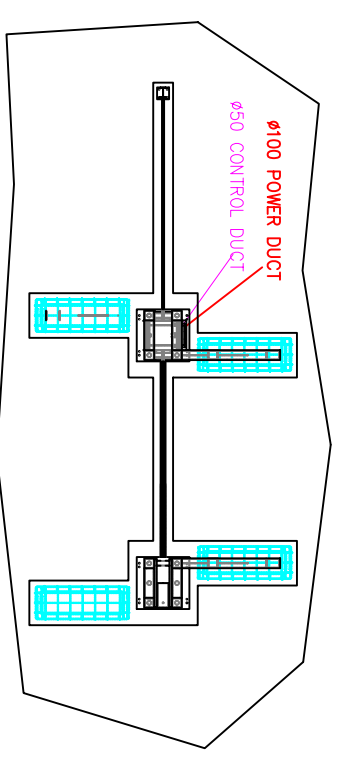

STAGE 6
TERMINATE DUCTING AND SEAL OFF.
POUR CONCRETE AROUND A FRAMES UP TO THE F.F.L. ENSURE FRAMES DO NOT MOVE DURING SECOND POUR.

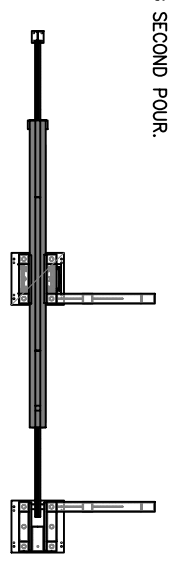

STAGE 7
ADD GATE ASSEMBLY

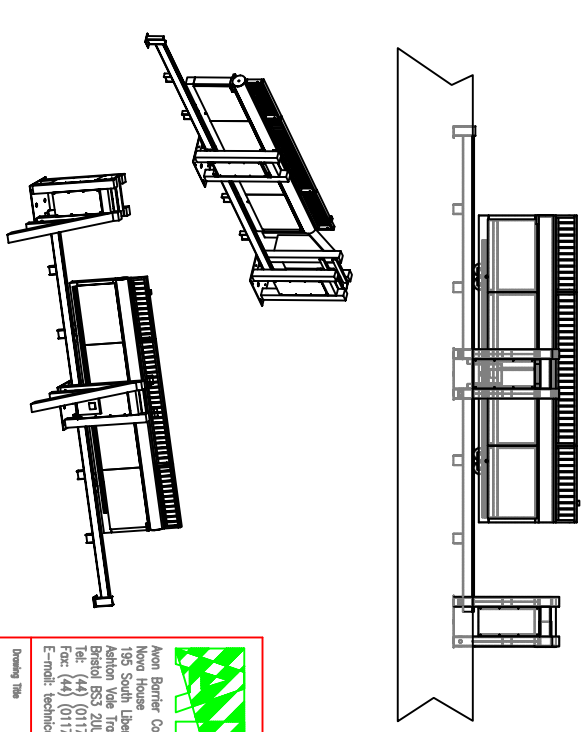

INSTALLATION
SEQUENCE
FOR CRASH GATE

Revised on	Drawn	Checked	Approved	Date	Scale
AS PER ABOVE	M.J			4/09	NTS

3rd ANGLE PROJECTION

COMPUTER GENERATED
DO NOT ALTER BY HAND

IF IN DOUBT ASK



Avon Barrier Company Ltd.
195 South Liberty Lane
Ashdon Vale Trading Estate
Bristol BS3 2JU
Tel: (44) (0117) 953 5252
Fax: (44) (0117) 953 5373
E-mail: technical@avon-barrier.co.uk