



Avon Barrier Company Ltd

**THE CHIEFTAIN RB780 CR.
HIGH SECURITY ROAD BLOCKER.**



Example Picture Only



©Copyright Avon Barrier Company Ltd 2009.

INTRODUCTION.

This manual provides information on the Avon Barrier Company Chieftain RB780 CR, Hydraulically operated High Security Road Blocker. It is designed to assist the Specifiers, Installers, Maintainers, Operators, System Integrators and Procurement Staff.

Should you require any further information or specific assistance please contact our security specialists at our UK Head Office.

Avon Barrier Company Ltd
Nova House
191-195 South Liberty Lane
Ashton Vale Trading Estate
Bristol
England
BS3 2TN

Tel : +44 (0) 117 953 5252

Fax: +44 (0) 117 953 5373

Email : sales@avon-barrier.com
technical@avon-barrier.co.uk

Website: <http://www.avon-barrier.com>

SCOPE OF DOCUMENT.

The RB780 CR shall hereafter be referred to as the 'Blocker' or 'RB780 CR'.

This document is intended for those who will:

Specify the site / system.

Design the secure entry system

Install / interface the Blocker

Operate the Blocker

Maintain the Blocker

IMPORTANT: Note for system/site designers.

The safe operation of the RB780 CR depends on a careful balancing of the various risk factors which are inevitably associated with operating a large piece of moving equipment in a public area.

Site specific risk assessments should be carried out and the mode of operation decided upon before the system specifications are made final.

Avon Barrier Company will be happy to provide advice and consultation services are available upon request.

TABLE OF CONTENTS.

INTRODUCTION.	2
<i>Scope of Document.</i>	2
<i>IMPORTANT: Note for system/site designers.</i>	2
TABLE OF CONTENTS.	3
<i>Table of Contents Continued</i>	4
<i>Table of Contents Continued.</i>	5
HEALTH AND SAFETY.	6
<i>Product Description.</i>	7
<i>Further Description.</i>	8
GENERAL SPECIFICATION.	9
<i>Physical dimensions:</i>	9
<i>Electrical requirements:</i>	10
<i>Construction:</i>	10
<i>Performance:</i>	10
<i>HPU Cabinet:</i>	10
<i>Hydraulics:</i>	10
<i>Hydraulic Cylinder.</i>	11
<i>Electrical:</i>	11
<i>Options:</i>	11
INSTALLATION.	12
<i>Health and Safety.</i>	12
<i>Personnel.</i>	12
<i>Installation Guidelines.</i>	13
<i>Installation Detail.</i>	13
<i>Blocker Base Preparation:</i>	14
<i>HPU Cabinet.</i>	14
<i>Ducting.</i>	14
<i>Installation; Mechanical / Hydraulic.</i>	15
<i>Installation Electrical.</i>	15
<i>Inductive Loop Systems. (If applicable).</i>	16
<i>Saw cut installations</i>	16
<i>Performed loop installations</i>	16

TABLE OF CONTENTS CONTINUED

COMMISSIONING.	17
<i>Manual Raise and Lower:</i>	17
<i>Power On Tests:</i>	18
<i>Motor Direction Check:</i>	18
<i>Raise and Lower Tests.</i>	19
<i>Pressure tests.</i>	20
<i>Operational Tests.</i>	21
<i>Handover Procedure.</i>	22
OPERATION AND MAINTENANCE.	23
<i>Manual Raise / Lower.</i>	23
<i>Access Control.</i>	24
<i>Hydraulic:</i>	24
<i>Explanation of Illustration Hyd-002.</i>	25
<i>hYDRAULIC sCHEMATIC rb780 cr hpu WITH fAST rAISE</i>	26
<i>Programmable Controller:</i>	27
<i>Limit Switches:</i>	27
<i>Raise operation:</i>	28
<i>Lower operation:</i>	28
<i>Motor Timeout:</i>	28
<i>Safety devices:</i>	28
<i>Site Secure facility:</i>	28
<i>Emergency Fast Raise:</i>	28
<i>Loop Detectors:</i>	29
<i>Safety Loop.</i>	29
<i>Free Exit Loop.</i>	29
<i>Auto Closing Loop.</i>	29
MAINTENANCE & REPAIR GUIDELINES.	29
<i>Fault finding.</i>	29
<i>Lower Input.</i>	30
<i>Raise Input.</i>	30
<i>Safety devices Input.</i>	30
<i>Site secure Input.</i>	30
<i>Limit switch.</i>	30
<i>Motor Timeout.</i>	30
<i>Loop Detector.</i>	31

TABLE OF CONTENTS CONTINUED.

<i>Periodic Maintenance.</i>	32
<i>Weekly maintenance:</i>	32
<i>Monthly maintenance:</i>	32
<i>Six monthly maintenance:</i>	32
<i>Annual maintenance:</i>	32
<i>Topping up the oil:</i>	33
<i>Changing the oil:</i>	33
<i>Cleaning the oil filter:</i>	33
<i>Adjusting the limit switches.</i>	33
<i>Bleeding air from the hydraulic system.</i>	33
<i>Installation Documents.</i>	34
<i>Risk Assess RB780 -inst.</i>	34
<i>RB780-1-014 Rebar.</i>	34
<i>RB780-6-001 Found.</i>	34
<i>RB780-6002 Stepin.</i>	34
<i>HPU found-large.</i>	34
<i>EB-1-01. saw cut loop</i>	34
<i>Risk Assess RB780 -maint.</i>	34
<i>NNN-2-01 Blocker electrical.</i>	34
DECLARATION OF CONFORMITY	35
WARRANTY AND LIMITATION OF LIABILITY	37
<i>HYDRAULIC HOSE SPECIFICATION</i>	39
<i>DINAMIC 2SN MD – EN 853</i>	39
<i>Hose Tolerances</i>	39
<i>Fitting Tolerance</i>	39
<i>HYDRAULIC OIL DATA SHEET</i>	40
<i>SUITABLE HYDRAULIC OILS.</i>	43

HEALTH AND SAFETY.



This symbol indicates a potentially hazardous situation that might result in injury or machine damage. It also indicates strict attention must be given to the instructions following this symbol.

Where associated equipment is supplied or fitted by others, the seller and purchaser of the equipment are responsible for ensuring that:

- The equipment complies with all Safety Requirements,
- The associated equipment does not adversely affect the operation or safety of equipment supplied by Avon Barrier Company Limited.
- It is the sole responsibility of the owner / user of the equipment to establish which legislation is applicable to the country in which the equipment is installed, and to ensure subsequent compliance with all national and local regulations.

It is also important that the owner/user of the equipment has assessed all equipment and operational hazards which might arise from the presence of electrical power, powered machinery and exposed moving parts, both pre and post-installation of the equipment. It is recommended that this assessment be reviewed before the equipment is set to work.

[ToC](#)

PRODUCT DESCRIPTION.

The Avon RB780 CR Chieftain is a Crash Rated Rising Blocker which provides a high level of security against unauthorised vehicle access.

Designed to withstand substantial direct impact forces, the Blocker has the ability to protect sites from extreme aggressive vehicular attack.



Chieftain RB780 CR Rising Blocker.

The RB780 CR has been fully crash tested in excess of U.S. DoS Standard K12/L3. It absorbed an impact in excess of 7610kg at 80 K.p.h. and remained fully operational.

It conforms to the B.S.I Specification PAS 68 – 1 for Security Barriers Part 1: Impact Absorption – 7610 Kg at 80Kph (Exceeds DoS Specification K12/L3)

Designed and manufactured by engineers with a wealth of experience in the fields of High Security and Access Control, the RB780 CR is a highly dependable security product that will easily interface with a wide range of control equipment.

[ToC](#)

FURTHER DESCRIPTION.

An hydraulically operated, 2m to 6m wide, crash rated vehicle blocker with up to 800mm lift. Comprising; static ground frame with hinged, rising impact wedge with curved 5mm steel skirt on security face and flat 8mm Durbar plate on the road face.

A single RB780 CR can protect a road width up to a maximum of 8 metres, (this is dependant upon site conditions and should be specified at the time of quotation/order.)

Raise & lower times 6-8 seconds. Optional emergency fast raise < 1 second.

The Hydraulic and Electrical controls are housed in the Hydraulic Power Unit cabinet (HPU) which is normally sited within 8 meters of the centre of the Blocker.

Access to the cabinet is via two removable doors, one at the front and one at the rear, these are secured using two cam barrel locks at the top of each door.

HPU cabinet and Blocker assembly are shot blasted, zinc primed and finished in a high quality

RAL colour coded paint.

The blocker may be operated by attendant from a local or remote control station (via intercom or C.C.T.V), or from a vehicle using a variety of Avon Access control options.



Illustration HPU-001. Cabinet large

The Blocker wedge has a single inspection hatch, to enable access for maintenance, which is fastened by six M16 steel, dome-head bolts. Steel side panels give access to limit switches and bearing blocks.

The supporting framework is constructed from fully welded, heavy gauge, steel angle and box section completely encased in galvanised steel sheet to provide a self-shuttered module.

Sub-surface fixing points, tie-bars and post installation fixings ensure the Blocker is completely secured to its foundation.

The impact Wedge is mounted on the Frame via an 80mm bright steel shaft in heavy duty bearing blocks with a 273mm x 9mm outer protection and support tube for impact absorption.

An anti-roll rail is fitted to the front edge to protect the hydraulic ram should there be an impact.

[ToC](#)

Units are assembled in our UK fabrication facility using heavy gauge materials to give maximum strength and durability, this makes the RB780 CR the ideal product to protect high security establishments.



Avon Barrier. Blocker fabrication facility.

GENERAL SPECIFICATION.

Physical dimensions:

Blocker segment width:	20000mm	3000mm	3500mm	4000mm	4500mm
Blocker frame width:	2510	3510	4010	4510	5010
Blocker frame length:	1800	1800	1800	1800	1800
Blocker frame depth:	1000	1000	1000	1000	1000
Excavation Width:	3430	4430	4930	5430	5930
Excavation Length:	2810	2810	2810	2810	2810
Excavation Depth:	1588	1588	1588	1588	1588
Dimensions are approximate.					

Standard HPU cabinet dimensions:
 Fast Raise HPU cabinet dimensions:
 HPU cabinet concrete foundation support:

W: 635mm x D 660mm x H 1300mm
 W: 935mm x D 660mm x H 1300mm
 W: 1100mm x D: 800mm x H: 300mm.

[ToC](#)

Electrical requirements:

Electrical Supply	Value	Tolerance	Comments
Supply Voltage (V ac)	415	+10%, -15%	240v single or 3 phase is available as a special order
Supply Voltage Frequency (Hz)	50		60 available as a special order.
Current Rating (A) (Current dependant on Equipment supplied and may vary)	20A		The Blocker should be protected by a type 'D' MCB
Maximum power cable size (mm2)	6		
Maximum signal cable size (mm2)	4		

Construction:

All welded steel construction, self-shuttering for ease of installation.
Pivot shaft: 80mm bright steel rotating in high impact nylon bearings.
HPU Cabinet - 2.5mm Steel housing and door.

Locking :

6 x M16 Dome head steel bolts securing the inspection hatch.
2 cam barrel locks on each HPU cabinet door.

Performance:

Axle weight limit : 30 Tonnes
Impact Absorption : 7610Kg at 80Kph Fully crash tested with no operational damage.
(Exceeds DoS Specification K12/L3)
Standard Speed of operation : 6 to 8 Seconds
Emergency Fast Raise (if specified) : < 1 Second

HPU Cabinet:

Constructed from 2.5mm steel plate, it houses the Hydraulic Power Unit (HPU), the operating mechanisms, manual hand pump and electrical enclosures.

Access is via two lockable removable doors.

The Electrical controls, relays and programmable logic controller (PLC) are housed in their own IP65 rated individual panel within the HPU cabinet.

A rotary mains disconnect switch to isolate the equipment for maintenance purposes, is fitted within the cabinet.

Hydraulics:

The Hydraulic Power pack uses an electric motor driven pump to actuate the hydraulic ram, this in turn raises and lowers the blocker wedge.

A hand pump for manual raise and lower facilities is provided and is incorporated in the HPU cabinet.

The hydraulic power pack oil tank is mounted at the base of the HPU enclosure and is fitted with an oil level \ temperature indicator. The positive displacement pump draws fluid from the reservoir, through a suction filter, and delivers it through double steel braided hoses (to EN853-2SN 10), at high pressure to the cylinder in the blocker. Raise / Lower directional control is provided by the use of a solenoid control valve.

Lift speed is derived directly from the pump capacity.

A relief valve prevents excess pressure being generated in the system and a flow control valve is fitted to allow adjustment of the lowering speed.

Where emergency Fast Raise or power fail backup is installed, the hydraulic ram may be powered from a pressurized nitrogen accumulator which can be sized to give single or multiple raise operations.

[ToC](#)

HYDRAULIC CYLINDER.

The hydraulic ram is of steel construction with a bore of 40mm, a nominal stroke of 430mm and a stainless steel piston. It is attached between the blocker base and the blocker wedge with two solid steel pins and locking rings.

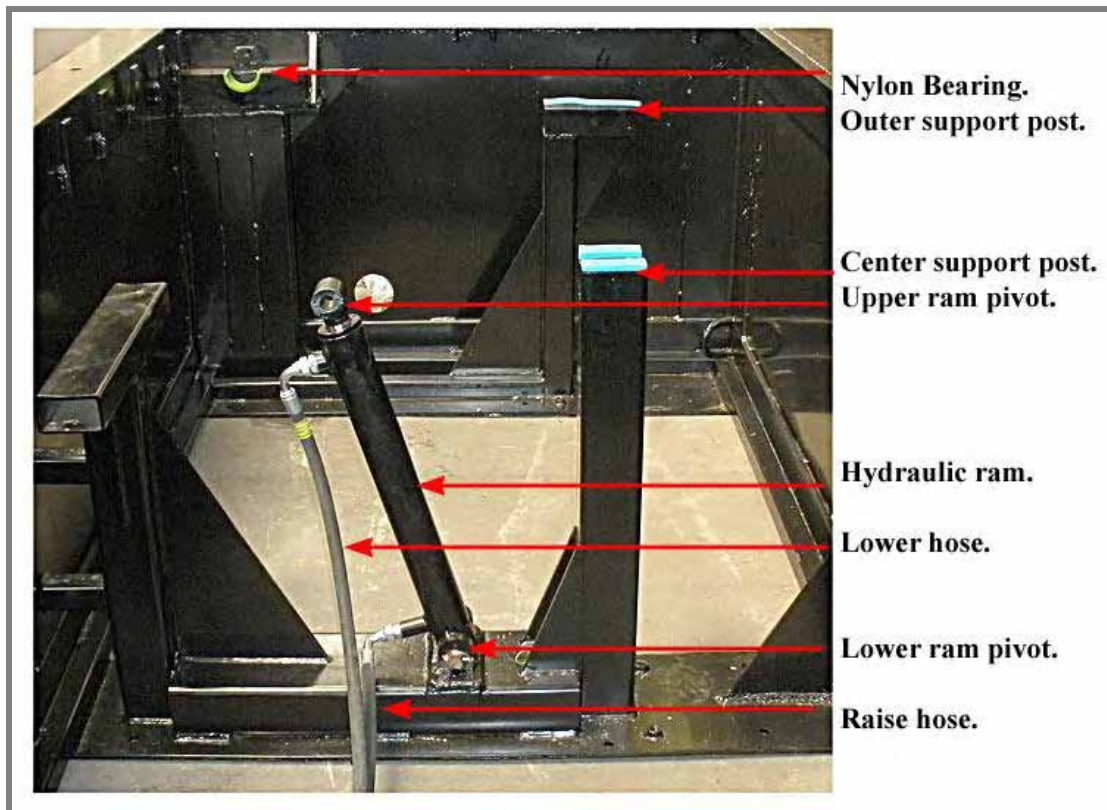

Illustration hyd.004 ram.

Electrical:

Standard supply requirements: 415v AC three phase 50/60 hertz, max 20 amps.

Supplies should be protected by a type "D" magnetic circuit breaker.

Cable entry is via conduit through the base of the HPU cabinet.

System control utilises a programmable logic controller which allows for a wide variety of configurations and control /monitor interfaces.

The hydraulic pump is driven by a 415v 3 phase motor. (other options available).

Hall effect type proximity switches are fitted at the side of the Blocker wedge and provide raised / lowered input signals to the PLC.

Options:

The installation will normally comprise a single Blocker across each entrance.

The PLC programmable controller allows many different modes of operation to be incorporated.

The Blocker comes with a simple raise and lower push-button control as standard, however it can be customised to interface with a wide range of access control equipment to suit specific customer requirements and any configuration including card readers and remote control systems, communication equipment and manned guard panic systems can be accommodated.

Safety systems can include; inductive road loops and photo cells.

Large head (200mm Diameter) red / green traffic lights can be provided with status signalling received from the PLC controller and back indication inputs.

Emergency fast raise, using hydraulic accumulators, can be provided to give a sub- 1 second raise time.

Power fail back up with UPS battery and hydraulic accumulators can be provided to allow the blocker to be raised and lowered in a power failure situation.

Where the control point is to be remote from the Blocker position, we strongly recommend the fitting of a recordable CCTV system, traffic lights, signage and safety inductive loop systems.

[ToC](#)

INSTALLATION.

Health and Safety.



It is the sole responsibility of the owner/user of the equipment to establish which legislation is applicable to the country in which the equipment is installed, and to ensure subsequent compliance with all national and local regulations.

It is also important that the owner/user of the equipment has assessed all equipment and operational hazards, which might arise from the presence of electrical power, powered machinery and exposed moving parts, both pre and post-installation of the equipment. It is recommended that this assessment be reviewed before the equipment is set to work.

Where associated equipment is supplied or fitted by others, the seller and purchaser of the equipment are responsible for ensuring that the equipment complies with all Safety Requirements and any associated equipment does not adversely affect the operation or safety of equipment supplied by Avon Barrier Company Limited.

Personnel.



The vendor should train one or more authorised persons, nominated by the employer, to be responsible for the installation of the equipment.

Training should include instruction on Safe Practices and known hazards.

All installation works must be carried out only by suitably qualified and experienced personnel, who are familiar with the risks and dangers inherent to their particular discipline, and the precautions necessary to minimise them.

Only carry out installation works;

When suitable warning signs are posted and area is cordoned off from traffic.

If no hazard exists (e.g. crushing hazard, slipping hazard, etc.)

With correct tools and equipment.

After carrying out the appropriate Risk Assessments.



Risk Assessments for the installation process are included in this document, it is strongly recommended that they are consulted prior to commencement of the installation.

They may be found in the Document section of this publication under the title:

Risk assess RB780CR-inst.

[ToC](#)

INSTALLATION GUIDELINES.

Installation may be broken down into the following stages:

Excavation of Blocker pit.

Installation of 100mm conduit for hoses and signal cable.

Construction of sump pit (if required)

Installation of drainage pipes.

Fabrication of rebar cage.

Construction of Blocker foundation base.

Installation of Blocker unit.

Backfilling of Blocker pit.

Installation of inductive road loops (if required).

Mounting of traffic lights (if required).

Construction of HPU cabinet base.

Installation of conduit for power / signal and access control cables.

Pulling of cables and hoses.

Positioning of HPU cabinet.

Connecting power cables and hoses.

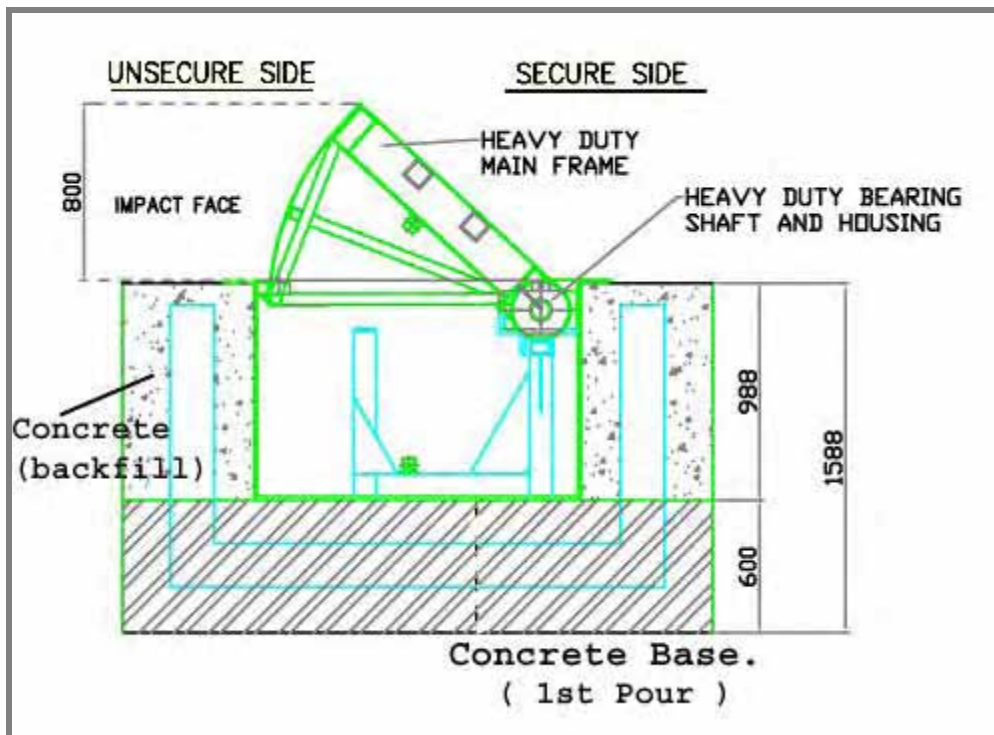

Illustration RB780-6-001.detail.

Installation Detail.

Crash rated road blocker;

To be installed across the roadway with the curved edge of the rising wedge fitted on the insecure (attack side).

The wedge pivot points are to be positioned on the secure side of the site.

The blocker may be sited on a rising or falling road surface and allowed to follow the line of the slope, however, the blocker must be mounted level across the camber of the road.

Provision *must* be made for drainage of water from the inside of the blocker.

If the Blocker is to be sited in an area which is susceptible to flooding or a high-water table, a sump pit must be provided in the blocker foundation and a suitable pump system used to keep the inside of the Blocker free of water.

A 100mm pvc duct (for the two hydraulic hoses and the signal cable) must be provided between the Blocker and the HPU cabinet.

[ToC](#)

Blocker Base Preparation:

Please consult the following drawings, which can be found in the reference section of this manual:
RB780-1-014 Rebar. Drawing providing dimensions for fabrication of re-bar sections.
RB780-6-001 Found. Drawing giving dimensions of blocker and concrete foundations.
RB780-6-002 Stepin. Drawing giving step instructions for blocker installation.

Base to be 600mm deep, steel reinforced raft foundation, (with drain outlet unless sump pit is required).
Recommended concrete type is C35 grade with reinforcement in accordance with the drawing for both base and walls.
Finish should be levelled and trowelled or brushed.
A drainage point leading to storm water drainage or a soak away or a sump pit must be included in the base design.
Backfilling: Once the base is cured, the Blocker can be craned into position and levelled using shims as necessary, the unit should be fixed in place using the internal fixing points to prevent movement whilst back pouring.
The ducts should then be fed into the Blocker and the base and any openings should be sealed, using Flexi-foam or equivalent, to stop the ingress of concrete.
The walls can then be poured around the unit to a minimum thickness of 600mm, and brought right to the underside of the edge angles of the Blocker.
It is important that the concrete is brought up to a level flush with the top surface of the Blocker, with no air pockets beneath the Blocker top overhang.

HPU Cabinet.

Containing hydraulic power pack, drive unit and electrical control equipment, it should ideally be fitted within 8 meters of the centre of the Blocker unit.
Where the distance between the HPU and the Blocker exceeds 8M, steel piping may be required in place of the standard hoses. (Please contact Avon Barrier Company Ltd. for further details.)
Should a pair of Blockers be controlled by a single HPU, the cabinet can be mounted either at the roadside or on a central traffic island.
The cabinet should be positioned in such a way as to allow access to both doors and should be sited in an area free from flooding. It should be mounted on a concrete platform as per the drawing; *HPU Cabinet foundation large*.
(If the site already has a 300mm deep hard standing and is in an area not liable to flooding, then the concrete base may be omitted).

The HPU Cabinet should be fixed on the prepared base with M12 chemical anchor bolts or equivalent.

Ducting.

From beneath the rear of the HPU cabinet, separate ducting must be provided for the following cables:
Access control point (guard room or card reader post etc).
Power distribution point.
100mm duct to the Blocker (for the two hydraulic hoses and the signal cable).
Traffic lights. (if fitted).
Induction road loops, (if fitted).
Avoid 90° sharp bends and sharp edges.
The size of conduits will depend on the number of Blockers operated from the HPU.
All conduits should be fitted with draw wires.

[ToC](#)

INSTALLATION; MECHANICAL / HYDRAULIC.

All hydraulic pipes are of double braided construction to EN853-2SN 10 rated at 330 Bar.

A specification sheet may be found in the reference section of this manual.

Hoses should be run between the HPU and the Blocker in 100mm PVC ducting.

All joints in the conduit should be smooth and free from sharp edges and burrs to prevent scoring the hose outer sheath during installation and Blocker operation.

Hose length should be sufficient to allow for some slack in the HPU cabinet for expansion or shrinkage.

When fitting the hoses care should be taken to not allow contamination from dirt, water, swarf etc.

This is done by flushing new hoses prior to fitting and capping off any open ends/connectors.

The hydraulic ram may be accessed through the inspection hatch fitted in the centre of the blocker wedge. Using a 10mm Allen wrench, remove the six 16mm dome head retaining bolts and lift the cover off.

The blanking caps should be removed from the ram and hose ends and the hoses connected to the appropriate fitting points and tightened.

The other end of the hoses should be attached to the numbered fittings in the HPU cabinet and tightened.

(The hoses and associated fitting points on the ram and HPU are marked.)



Under no circumstances should anyone be in the Blocker when it is not fully lowered.

Prior to entering the lowered Blocker, all electrical supplies are to be isolated and locked off and the oil pressure reduced to zero. As the Blocker may be classified as a confined space the appropriate Method statement and Risk Assessments should be in place and gas samples should be taken prior to entering the Blocker and continuously monitored whilst work is undertaken.



Electrical installation must be in accordance with current local regulations



All cable sizes must conform to Blocker electrical specification and current local regulations.

Power cables must be routed in separate conduit from signal cables.

The electrical equipment is located inside an IP65 rated enclosure mounted inside the HPU cabinet above the hydraulic power pack.

A 415v 3 phase mains supply cable should be connected to the isolator switch mounted below the electrical enclosure, and the cabinet frame should be earthed.

The signal and control cables should be brought into the electrical enclosure through the glands and connected to the appropriate DIN rail mounted terminals.

A generic wiring diagram is included in the document section of this manual, it should only be used for reference purposes as the site specific drawing will be different.

Copies of site specific wiring diagrams will be shipped with the equipment and will be found stored in the electrical enclosure.

[ToC](#)

Inductive Loop Systems. (If applicable).

Two types of loop installation may be used. For existing roadways, saw cut loops are most cost effective. Preformed loops encased in PVC conduit or trunking must be used in installations under block paving.

Loop size may vary and will depend upon lane width. The standard size would be 1000mm across X the width of the Blocker wedge and a depth of 30 to 40mm.

Four turns of wire is usually sufficient for most applications. (See *loop detector manual for details*).

Loop wires should not be installed above reinforcing steel, electrical cables, steel conduit or water pipes.

Saw cut installations

The slots must be 30-40mm deep and clean, with no sharp corners which could damage the cable insulation and just wide enough to accommodate the type of cable being used.

Refer to drawing EB-1-01 in the reference section of this manual.

The wire used for the loops should be 1.5mm sq and have an insulation rated for direct burial as moisture can cause significant loop frequency drift.

When the cable is laid, ensure that no insulation is protruding above road level.

An appropriate sealant should be used dependant upon the finished road surface, i.e. mortar dry mix, brushed into the loop slot, or hard setting epoxy for concrete roadways and bitumastic for tarmac roads. Caution should be taken when using hot fill sealant, as the high temperatures could damage the insulation.

The loop should be installed in one continuous run, the tails of the loop should be twisted together from the point of leaving the loop to the terminations in the HPU.

The tail should have no fewer than 20 turns per metre.



Use Extreme caution when using hot-fill bitumen to backfill.



Keep burner and gas within view but away from the immediate working area and protect from collision or persons.

Use appropriate gloves and goggles, with standard PPE, when handling the hot bitumen and always keep an appropriate fire extinguisher handy.

When using a cement compound to backfill be aware of the risk to health from cement dust and wear appropriate gloves and face mask to protect from inhalation.

If using a chemical compound to backfill, read all of the manufacturers literature and comply with all Health & Safety instructions given.

Preformed loop installations

The loops are usually manufactured, upon request, prior to installation.

The cable is housed in a PVC conduit or trunking to provide mechanical protection, with the twisted tails exposed. These loops are then laid in the roadway in their final location and embedded into sand.

The block paviors/paving are then placed over the top and firmed down as normal.

Care should be taken not to crush or damage the trunking or cable when installing the cabling.

It is advisable to perform an earth leakage (Megger) and loop resistance test prior to commissioning the loop.

[ToC](#)

COMMISSIONING.

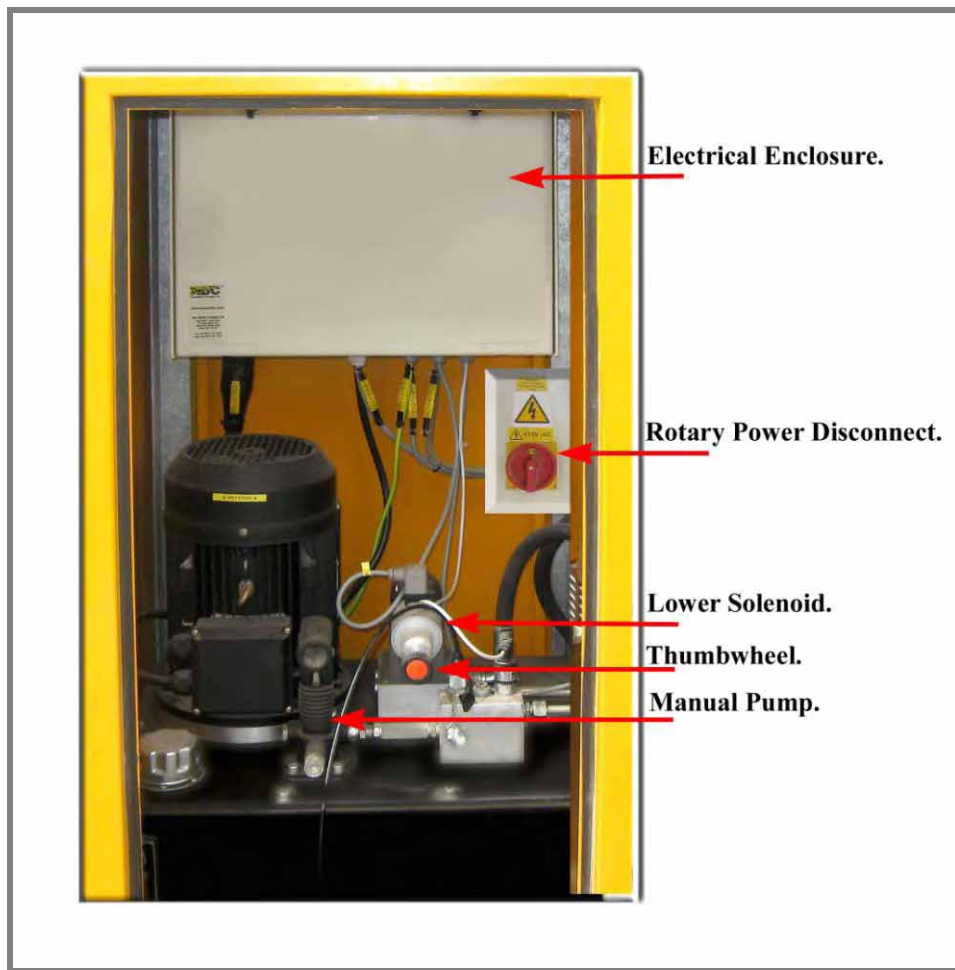

Illustration HPU-002. Cabinet.

Ensure that the Blocker transit straps have been removed. These are two steel strips bolted across the blocker frame and the front of the rising wedge.

Manual Raise and Lower:

Refer to: *Illustration HPU-002. Cabinet.*

The Blocker should initially be raised and lowered using the manual pump in the following manner:

Insert the pump handle (stored behind the vertical frame strut), into the manual pump socket and pump up and down until the blocker raises.

It may require several strokes to build up the initial pressure.

If the Blocker appears to be lowering, then it is possible the hoses have been connected the wrong way round and this should be checked and rectified.

The Blocker may then be lowered by using the manual pump in conjunction with the Lower solenoid: Turn the solenoid thumbwheel clockwise until finger tight

(do not overtighten) pump the handle up and down until the Blocker lowers.

Check for oil leaks at both ends of the hoses and tighten where necessary.

Check all fastenings and mounting bolts are secure.

Check Blocker is centrally located within the frame and that the limit switch pick-up lugs are in line with limit switches.

Check hydraulic fluid level is above the minimum level on sight glass.

Top up oil if necessary.

See C.O.S.H.H sheets included in the documents section of this manual for handling precautions.

[ToC](#)

POWER ON TESTS:



The authorised site electrician should now switch the mains power ON and make the appropriate tests in compliance with local safety regulations.

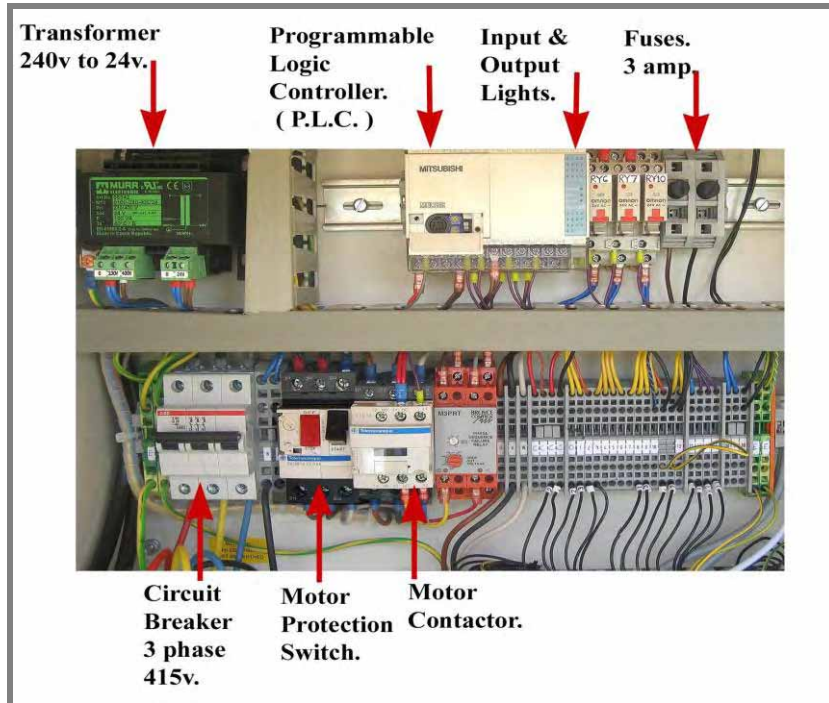

Illustration elec-001.Control Panel.

Motor Direction Check:

Set the PLC to 'Off' by using the micro-switch located under the front cover on the PLC
Refer to: *Illustration elec-002. PLC.* then switch the Mains power on at the MCB circuit breaker and at the Rotary Disconnect switch. Refer to: *Illustration elec-001.Control Panel.*

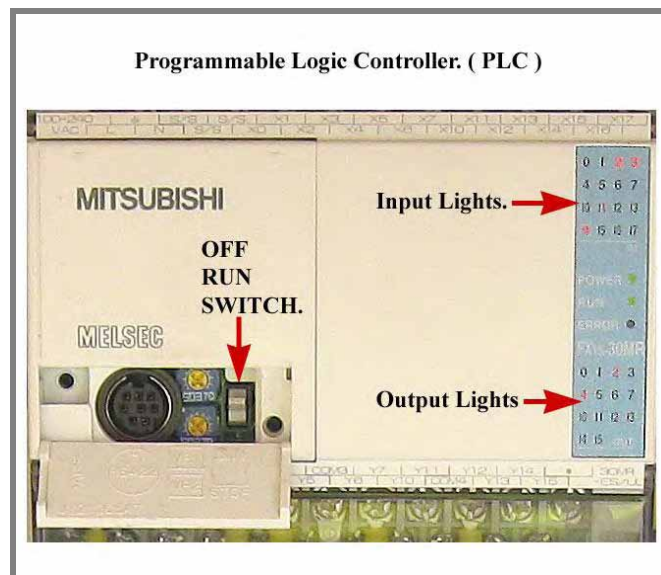

Illustration elec-002. PLC.

[ToC](#)

The PLC Input and Output designation is site specific and a designation sheet will be found with the electrical schematics stored in the electrical enclosure.
This sheet should be to hand when carrying out the following procedures.



Equipment will now be live, observe all safety precautions for working near live equipment.

Locate the Motor contactor; refer to: *Illustration elec-001.Control Panel.*

Using an insulated screwdriver, firmly depress the central segment.

The motor should turn whilst the contactor is depressed.

Check the direction that the motor is spinning by observing the fan blades .

The correct motor direction is indicated by the arrow on the fan cowl.

If the motor spins in the wrong direction then swap two of the incoming phases until it spins correctly



**Power off the Electrical panel at the MCB switch and at the rotary disconnect switch
before swapping the cores.**

Raise and Lower Tests.

Using the motor contactor, fully raise the blocker and check the limit switch indication on the PLC.

The Raised limit Input Light should be OFF and the Lowered limit Input light should be ON.

Note: The Blocker limit switches are fitted at the left side of the Blocker frame and can be accessed by removing the side inspection plate.



Side plate in position.



Sideplate removed for access to limit switches.

[ToC](#)

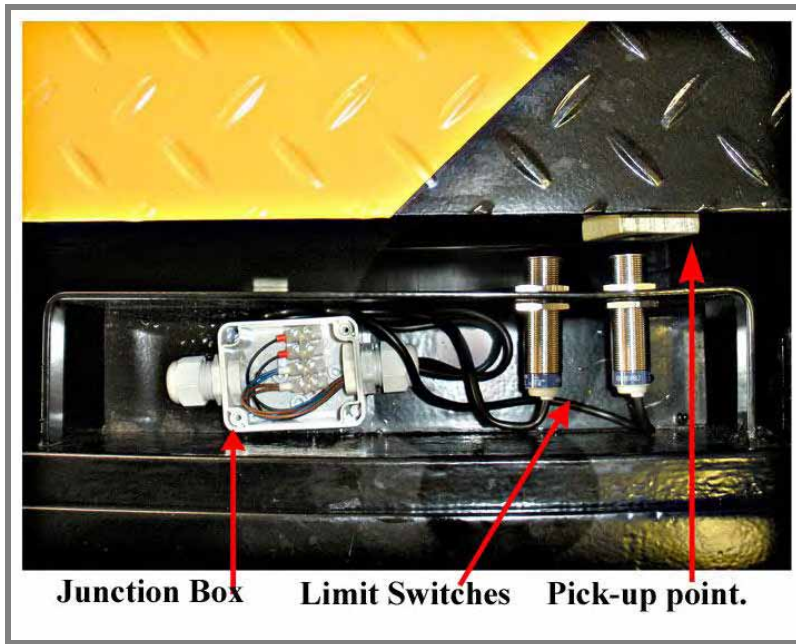

Illustration elec-003.Blocker limits

The limit switches are Normally Closed contacts and therefore the indicator light will go OFF when the detector is triggered.
*When the Blocker is in the Raised position the LED on the Raised limit switch and the input indicator lamp on the PLC will be OFF.
 When the Blocker is NOT in the Raised position they will be ON.*

Turn in the thumb-wheel on the lower solenoid and then, using the motor contactor, lower the blocker as far as it will go and check the limit switch indication on the PLC.
 The Raised limit Input Light should be ON and the Lowered limit Input light should be OFF.
 Turn the thumb-wheel on the solenoid several turns out to its normal position.
*When the Blocker is in the Lowered position the LED on the limit switch and the input indicator lamp on the PLC will be OFF.
 When the Blocker is NOT in the Lowered position they will be ON.*

Pressure tests.

Attach a suitable pressure test gauge to the test point located on the hydraulic manifold block.
 Refer to *illustration hyd-001*.
 Raise the Blocker using the motor contactor and note the pressure reading during raise.
 When the Blocker has reached its maximum raise height continue to hold the motor contactor and allow pressure gauge to stabilise, observe and note the maximum pressure reading.
 Lower the Blocker using the lower solenoid and note the pressure reading during lowering.
 Stop the motor. Make sure lower solenoid thumb-wheel is released.

Test condition.	Reading in bar.
Forced fully raised. (Relief	
Maximum during raise.	
Maximum during lower.	

[ToC](#)

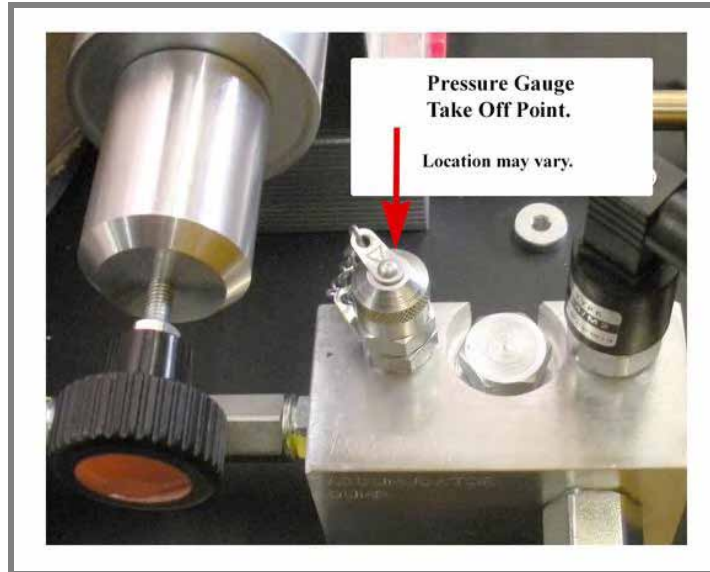

Illustration hyd-001. Pressure take off.

Remove the Blocker central inspection hatch and check the ram and hose connections for oil leaks. Check ram pivot pins and retaining clips. Replace and refasten the inspection hatch.



Disconnect power and isolate accumulator before removing inspection hatch.



Operational Tests.

Set the PLC to 'ON' by using the micro-switch located under the front cover on the PLC.

Refer to: *Illustration elec-002. PLC.*

Using the push button controller or other access control system, raise and lower the blocker several times.

The access control system can be simulated by using a short jumper wire to momentarily connect between the Common terminal and the Raise or Lower terminals on the terminal strip located at the bottom right of the electrical panel.

Check that the following systems, (if fitted) function correctly:

Access control equipment (pushbuttons / card reader etc).

Free exit induction loops.

Safety closing loops.

Traffic lights.

Safety induction loops.

Safety Photocells.

Fast Raise \ battery back up.

Interfacing with any other equipment.

Induction loops can be tested using any large steel object placed on the road above the loop, the loop detector unit fitted in the electrical enclosure should show an activation light.

Details of inductive loop detectors can be found in the fault finding section of this manual.

Carry out test sequences to prove that the system functions in accordance with the works instruction.

Leave the Blocker in the fully raised position for several hours and check for Blocker 'creeping' down.

It is recommended that the blocker is operated as many times as is practicable, preferably with vehicles crossing it, and then the limit switch operation and oil levels are double checked before handing over the system to the client.

[ToC](#)

HANDOVER PROCEDURE.

Demonstrate power isolation using MCB and Rotary switch.	
With mains power OFF ; Demonstrate the use of the Manual pump to raise and lower the Blocker.	
Mains power ON ; PLC to 'Run'. Raise & Lower the Blocker using jumper wire between Common and Raise / Lower terminals.	
Demonstrate use of access control system to operate the Blocker. (Including safety-closing and free exit loops if fitted.)	
Demonstrate that the traffic sequencing functions according to the works instruction; traffic lights / interlock etc.	
Demonstrate Fast Raise operation and accumulator isolation procedure.	
Confirm the raise and lower speeds.	
Demonstrate power fail back up system.	
Demonstrate the functioning of inductive loop detectors; observe LEDs as loop is triggered	
Demonstrate functioning of all safety systems.	
Inspect condition of installation ; paintwork, cabling, etc.	
Demonstrate oil top up / change procedure.	
Demonstrate relay change procedure.	
Demonstrate pressure adjustment procedure.	
Demonstrate limit switch adjustment procedure.	
Demonstrate periodic inspection procedures.	
Complete and hand over relevant paperwork, manual, keys etc.	

[ToC](#)

OPERATION AND MAINTENANCE.



Health & Safety.



Appropriate risk assessments should be carried out and operational methodologies should be agreed and established before the equipment is operated.

The owner should ensure that one or more competent persons are responsible for controlling the access system and advising vehicle users of the correct entry and exit procedures. Training should include instruction on safe practices and known hazards, including normal and emergency use.

Operators and attendants should be directed NOT to operate the Barrier unless the area is clear and all covers / guards are in place.

The 'Site Details' section of the final commissioning / handover document will give site specific details of the equipment fitted and its mode of operation. This should be studied in conjunction with the rest of this manual.

Training and certification of Operations and Maintenance personnel can also be provided upon request by Avon Barrier Company Ltd.

Manual Raise / Lower.

Manual operation of the Blocker in the event of power failure:



Before attempting manual operation, ensure that the electrical power is switched off



**Do not attempt to operate if there is evidence of failure of any hydraulic components –
Call Maintenance Engineer for assistance.**

Make sure the area around blocker is free from obstruction and is isolated from pedestrian and vehicular traffic.

Refer to: *Illustration hpu-001.Cabinet.*

Insert the pump handle (stored behind the vertical frame strut), into the manual pump socket and pump up and down until the blocker raises.

The Blocker can be lowered by using the manual pump in conjunction with the Lower solenoid:
Turn the solenoid thumbwheel clockwise until finger tight (do not over tighten).
Pump the handle up and down until the Blocker lowers.
Turn the solenoid thumbwheel anti-clockwise several turns.

[ToC](#)

Access Control.

Opening and closing is usually achieved by a standard Avon Barrier push button controller, however other access control equipment may be used.

To operate the Blocker a signal is required going from normally open to closed, for a pulse length of not more than 1 second.

The 'Site Secure' push button (if fitted) will lock in the down position and can be released by twisting the button or using the key, (depends on type supplied).

Depending on the customer requirements, the 'Site Secure' facility may over-ride the safety systems and this should be taken into account when establishing operational procedures.

A wide variety of access control methods, safety systems and security requirements may be applied to the RB780 CR, these reflect the specific needs of individual sites and may include:

Site Secure facility which over-rides safety devices.

Site Secure which does not over-ride safety devices.

Automatic induction loop triggered opening.

Automatic induction loop triggered closing.

Blocker / Barrier interlock system.

Hydraulic:

The RB780 CR Blocker, as standard, uses a three phase electric motor to drive a submersed high pressure positive displacement oil pump. The high pressure (max 220 bar) hydraulic fluid is applied, via two hydraulic hoses, to an hydraulic ram located inside the Blocker, thus lifting or lowering the blocking wedge segment.

Applying hydraulic pressure to the bottom of the ram will raise the blocker.

Applying hydraulic pressure to the top of the ram will lower the blocker.

An electrically operated solenoid valve changes the direction of flow of the hydraulic fluid;

When the solenoid is OFF and the motor is running, the blocker will raise.

When the solenoid is ON and the motor is running, the blocker will lower.

The following illustration is intended as a guide only.

Site specific details may vary with twin blocker or emergency fast raise systems.

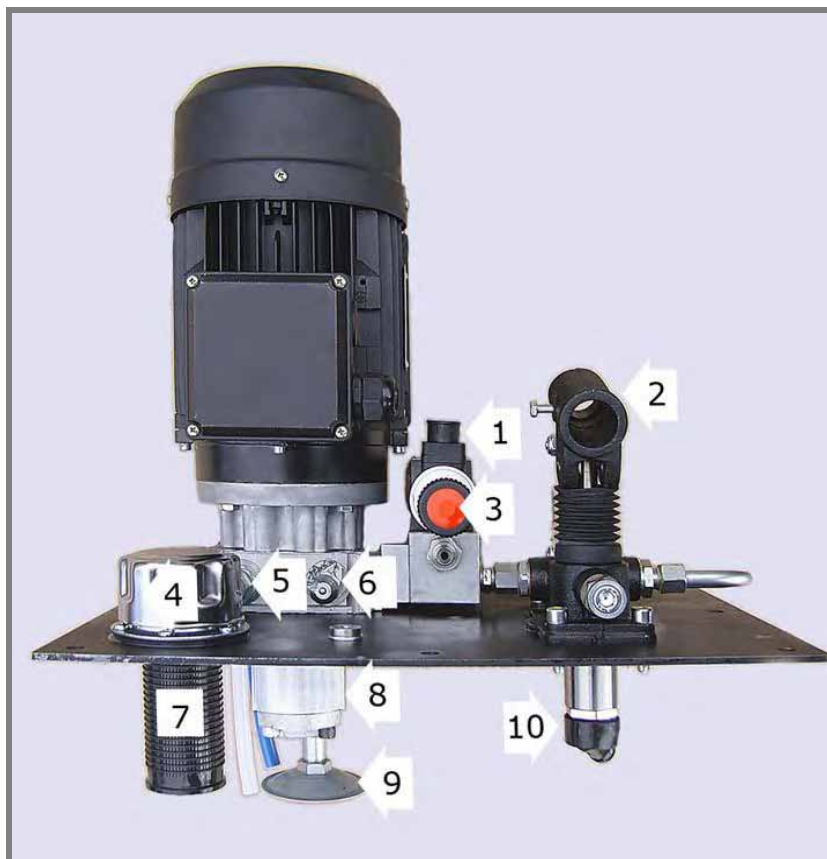

Illustration Hyd-002. Blocker/Barrier HPU.

[ToC](#)

EXPLANATION OF ILLUSTRATION HYD-002.

1: The solenoid acts to change the direction of flow of the hydraulic oil.

When OFF, the pressurised fluid is directed to the bottom of the ram with the fluid returning to tank from the top of the ram, this will raise the blocker.

With the solenoid ON, the fluid is directed to the top of the ram with return to tank being from the bottom, this will lower the blocker.

2: A manually operated pump allows the boom to be operated in case of power failure.

3: In the event of a power failure, the thumbwheel is used to manually operate the Lower solenoid to allow the hand operated pump to lower the blocker.

4: The oil filler cap is removed to top-up if required.

5: The pressure relief valve acts as a safety valve and will dump hydraulic fluid back to the tank if pressure exceeds the maximum setting. This valve is factory set and should not require any adjustment.

6: The pressure take-off point is used to connect a suitable pressure test gauge. It is fitted with a spring loaded self-closing valve and a removable dust cap.

7: The Oil strainer will act to filter any oil being added to the reservoir and prevents ingress of foreign objects when the filler cap is open.

8: Main high pressure oil pump is of the submersible type and draws fluid from the reservoir via the filter.

9: Intake to the high pressure pump. Filter screen acts to protect the pump from particles larger than 90 microns and is washable.

10: The manual pump draws its oil from this submerged intake.

[ToC](#)

HYDRAULIC SCHEMATIC RB780 CR HPU WITH FAST RAISE

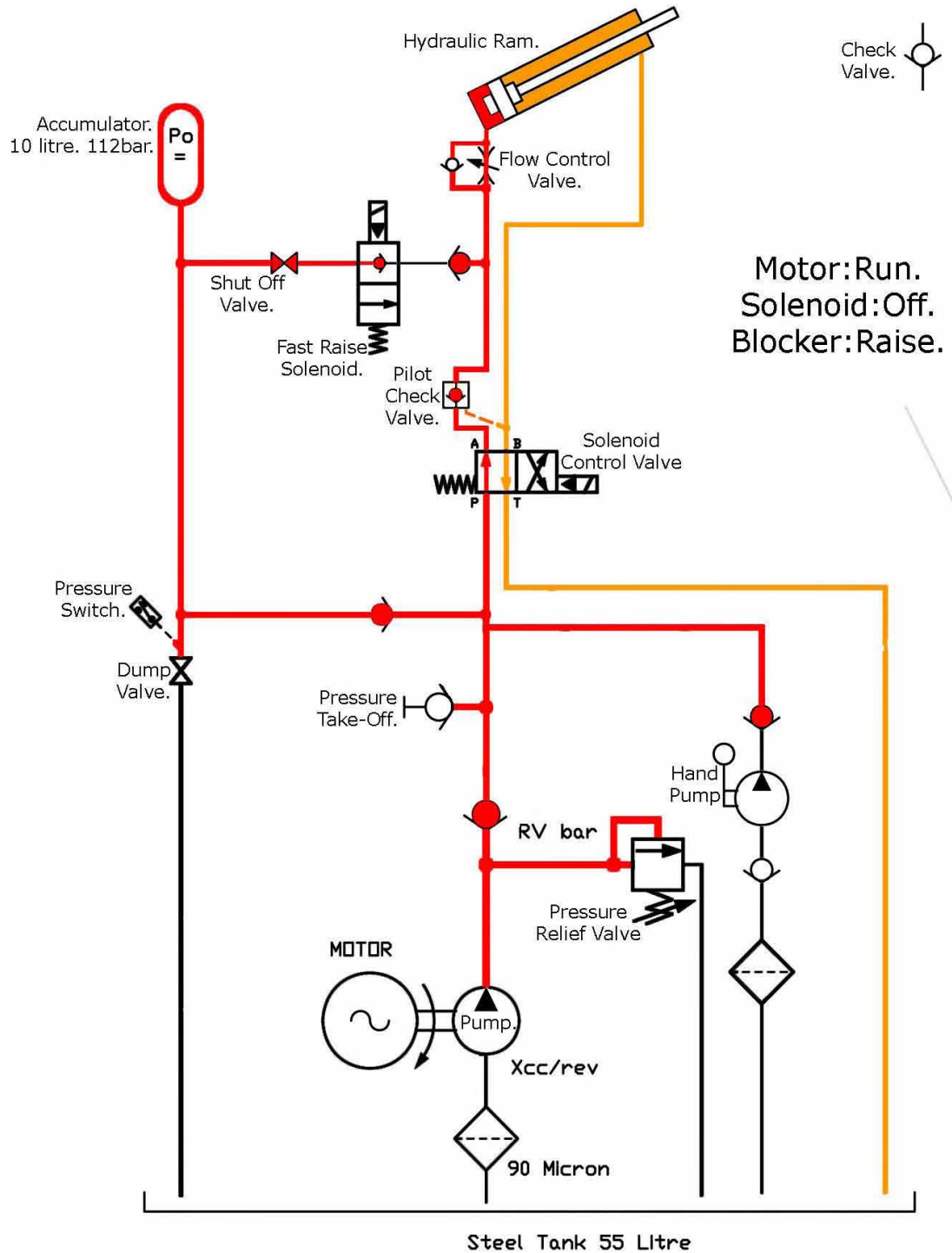
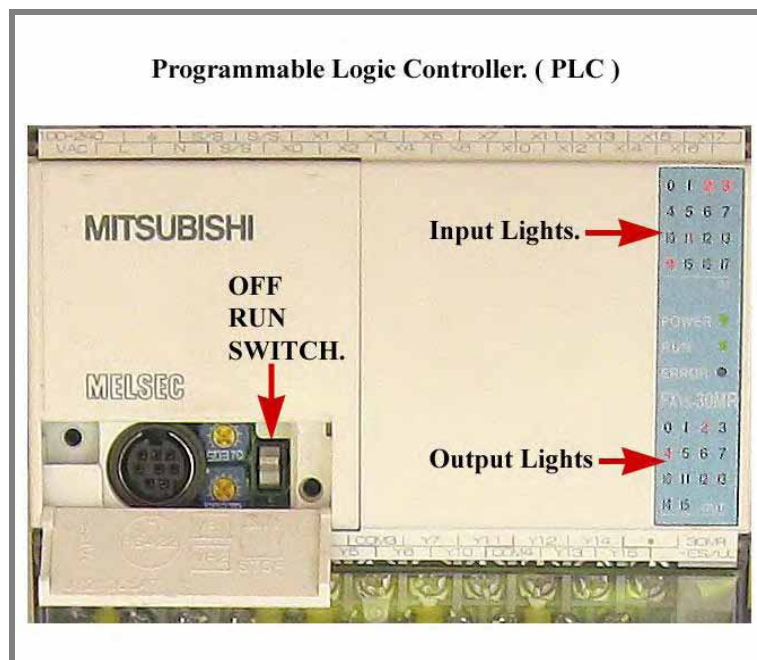

Illustration hyd-003. Blocker Accumulator Schematic.

The above schematic illustrates an Hydraulic Power Unit supplied with optional fastraise circuit. Site specific HPU's may vary slightly but will operate on the same principles.

[ToC](#)

PROGRAMMABLE CONTROLLER:



A Mitsubishi programmable logic controller (PLC) is used to operate the system and monitors the inputs and controls the outputs: It is located inside the electrical control panel and is invaluable in fault finding. A range of indicator lights at the top of the unit give information about the Inputs with a similar group at the bottom of the unit giving information about the Outputs. These inputs and outputs are listed, along with their functions and contact type (normally open or normally closed) in the PLC Input / Output sheet supplied with the equipment (shipped in the electrical enclosure).

Making a note of which I / O indicators are lit and the position of the blocker at the time can be of great benefit in determining the fault.

On the front lower left of the PLC is a small drop down flap which gives access to a micro toggle switch. This switch has two positions; Run and Off and can be used to reset the PLC by toggling OFF and then back to ON, or to switch the programming off while leaving the rest of the circuitry live for testing and fault finding.

Inputs come from:

Access control equipment (open / close push button etc),
Proximity switches. (actual position of blocker)
Safety equipment (road loops, photo cells etc).

Outputs go to:

Motor contactor; starts and stops motor..
Solenoid.; raises the Blocker when ON .
Traffic lights; lights show green when output is ON.(if fitted).
Back indication.; provides clean contact indicating blocker position .

Limit Switches:

The raised and lowered positions of the Blocker are monitored using two proximity detectors fitted to the Blocker at the left side of the frame.

They can be accessed by removing the steel cover plate at the left edge of the Blocker.

Proximity detectors (limit switches) are 'Normally Closed', therefore :when the blocker is raised, the Raised limit switch will be OFF.

When the blocker is lowered, the Lowered limit switch will be OFF.

Each limit switch has an L.E.D. indicator light on the back of the switch, this will be ON when the switch is NOT detecting and will go OFF when the switch is in the proximity of the pick-up point which is fixed to the side of the rising wedge.

[ToC](#)

Raise operation:

Blocker is lowered . Lowered limit switch is OFF. Raised limit switch is ON.
Operator presses the Close Lane button:
The PLC detects 'Close Lane' closed circuit and checks the safety device input;
if the input is closed circuit then the PLC closes the motor contactor circuit and the motor runs :
Blocker Raises: The lowered limit switch is now ON. The raised limit switch remains ON.
As the Blocker reaches the raised position the raised limit switch turns OFF.
The PLC detects the raised limit open circuit and opens the motor contactor circuit, this switches OFF the motor.
Blocker is now raised . Raised limit switch: OFF. Lowered limit switch is ON.

Lower operation:

Blocker is raised. Lowered limit switch is ON. Raised limit switch is OFF.
Operator presses Open Lane button:
The PLC controller detects 'Open Lane' closed circuit and closes the 'lower' solenoid circuit, the solenoid energises, the PLC closes the motor contactor circuit and the motor runs. Blocker lowers.
As the Blocker lowers, the raised limit switch turns ON. Lowered limit switch remains ON.
Blocker reaches the lowered position and the lowered limit switch turns OFF.
The PLC controller detects 'lowered limit' open circuit and opens the motor contactor circuit which stops the motor, PLC then opens the 'lower' solenoid circuit which switches OFF the solenoid.
Blocker is Lowered . Lowered limit switch is OFF. Raised limit switch is ON.

Motor Timeout:

If the motor runs continuously for more than one minute, the controller will enter a 'Timeout' mode and the output 'O' will illuminate. This can be reset by switching the mains power off and on again or by switching the PLC to 'OFF' and then back to 'RUN'.

Safety devices:

Depending on site specifications, various safety devices may be fitted e.g.
Induction loops to detect vehicle presence, photocells to detect vehicles or persons, safety edge sensors to detect contact with vehicles or persons.

Site Secure facility:

Some sites may have a Site Secure mode whereby if the blocker is lowered or lowering and the site secure button is pressed, then the blocker will stop lowering and will raise.
This may over-ride the safety device circuit, depending on the system specification.

Emergency Fast Raise:

Equipment may be fitted with hydraulic accumulators to provide an emergency fast raise facility which will raise the Blocker in less than one second. It may also be used, in conjunction with a battery back-up, to provide the ability to raise the Blocker in the event of a power failure.



Emergency fast raise systems will normally over-ride the safety systems therefore extra care should be taken when operating or working on them. An isolation valve is provided to allow isolation of the accumulator from the rest of the hydraulic system.

[ToC](#)

Loop Detectors:

Some systems may be fitted with inductive loop detectors, the loop is buried a few centimetres beneath the road surface and is connected to a loop detector unit mounted in the main electrical enclosure. Loop detectors may serve one or more of the following functions:

Safety Loop.

When a vehicle is on this road loop, the detector unit opens the safety circuit which then inhibits the PLC from activating the 'Close' mode.

Free Exit Loop.

Loop detector used to provide a 'free exit' mode whereby a vehicle approaching the Blocker drives onto a road loop, the loop detector then closes the 'Open' Circuit and the Blocker will lower automatically.

Auto Closing Loop.

Loop detector used to provide an automatic closing mode whereby a vehicle leaving the road loop causes the detector to close the 'Close' circuit thus automatically raising the Blocker. Often used in conjunction with 'free exit' mode.



Loop detectors cannot be relied upon to detect bicycles, motorcycles and non-ferrous framed vehicles



MAINTENANCE & REPAIR GUIDELINES.

Fault finding.

If a fault condition should occur the following steps should be taken:

Try to determine the exact nature of the fault i.e. Blocker

Will not raise,

Will not lower,

Raises slowly,

Does not lower fully etc.

Check that the power supply is ON.

Carry out a visual inspection of the equipment, look for any signs of damage.

Check inside the cabinet for signs of oil leaks and check the oil level.

Switch the power supply off, using the rotary disconnect switch in the HPU cabinet, wait a few seconds and then switch back on. This will reset the programmable controller and the Induction loop detectors (if fitted).

Check if fault has cleared.

If the fault has not cleared or if it re-occurs after operating the system, then use the following guidelines.

The input and output lights on the programmable controller (PLC) should be read and a note made of which lights are on. *Refer to illustration elec-002.*

Check that the input and output indications on the PLC match the current status of the Blocker.

Use the site specific PLC input/output information sheet.

Use the following list of fault finding guidelines in conjunction with the PLC input / output display.

[ToC](#)

Lower Input.

Use the access control system to open the lane (lower blocker) and observe the input indicator on the PLC which should show on and off condition if the open lane button is repeatedly pressed.
Alternatively a jumper wire can be used between the 'common' and 'open' terminals on the main terminal block.

Raise Input.

Use the access control system to close the lane (raise blocker) and observe the input indicator on the PLC which should show on and off condition if the close lane button is repeatedly pressed.
Alternatively a jumper wire can be used between the 'common' and 'close' terminals on the main terminal block.
If a Site Secure facility is provided, the blocker will raise and over-ride safety devices, therefore if the blocker will not raise using the normal raise (lane close) circuit, but will raise using the Site Secure circuit, then this can be used as an indication that the problem may be in the safety device circuit.

Safety devices Input.

Check that the PLC display is showing a closed indication for the safety device input.
If an open circuit is indicated then check the safety devices.
i.e. check photocells, safety edges and induction loop indicators.
Refer to the site specific wiring schematic stored in the electrical panel enclosure.
Safety devices can be jumpered across at the terminal block, one at a time, to narrow down the active device.
Note; an open circuit condition in any of the safety devices will prevent the blocker from lowering but should not prevent it from raising.

Site secure Input.

Check that the PLC display is showing a closed indication for the site secure input.
If an open circuit is indicated then check the site secure push buttons are not locked in the ON position.
An open circuit condition will raise the blocker and will also prevent it from lowering.

Limit switch.

Limit switches that are out of adjustment can cause a variety of faults;
Blocker not raising, Blocker not lowering, Blocker stopping halfway, Blocker cycling up and down.
If two Blockers are interlocked to work together in a 'trap' formation then a limit switch problem on one Blocker may prevent the other Blocker from working.
The limit switch is equipped with an LED indicator next to the cable entry point.
Check that this lamp is lit when not near to the metal pick-up point, then check the lamp goes out when near to the pick-up point.
A spanner or other metal object may be used to check for activation of the limit switch.
Whilst activating the limit switch, check for correct input indication at the PLC .
Observe the PLC input lights and check with the PLC Input/output information sheets to make sure that the correct limit switch is operating at the correct time.

Motor Timeout.

If the motor runs for more than one minute, a timer in the PLC will cause the system to enter the 'Timeout' mode. The output '0' will be lit.
This can be cleared by using the micro switch on the PLC and switching it to OFF then back to RUN
The PLC can be 'reset' by switching off the mains power for a few seconds and then switching back on.

[ToC](#)

LOOP DETECTOR.

The loop detector unit can usually be found in the top right of the electrical panel. Different models may be fitted, depending on site specifications, but basic functions remain similar, the status LED on the front of the detector unit should change colour as a vehicle or other metal object passes across the road loop. This can be tested either using a vehicle or a steel object laid on the road over part of the loop.

Sensitivity can be adjusted and frequency can be changed. User instructions may be found on the front and side of the detector unit or in the information sheet supplied with the equipment.

Note that the detectors are self-adjusting; if the mains power is switched off, when it is switched back on again the detector will measure the inductive field and reset itself to match its surroundings. This can be used to reset a detector that is outside its correct range. Care should be taken to see that no vehicle or other metal object is on the loop area when the mains power is switched back on as this may cause false detections.

Manufacturers instruction sheet for Loop detectors may be found in the reference section of this manual.



Illustration Elec-005.Nortech loop detector



Illustration Elec-006.USTC loop detector

[ToC](#)

PERIODIC MAINTENANCE.



Risk Assessments for the maintenance process are included in this document, it is strongly recommended that they are consulted prior to commencement of any maintenance tasks.

Only carry out maintenance works;

When suitable warning signs are posted and area is cordoned off to traffic.

If no hazard exists (e.g. crushing hazard, slipping hazard, etc.)

With correct tools and equipment. After carrying out the appropriate Risk Assessments.

Weekly maintenance:

Observe Blocker in operation and check for:
Erratic operation. Unusual noises. Damage to safety devices.
Operation of traffic lights and induction loop systems (if fitted).
Open cabinet door and check for signs of damage and oil leaks.

Monthly maintenance:

Same as weekly checks but additionally:
Use sight glass on front of oil tank and check oil level; top up if required.
Remove the Blocker inspection hatch and check the hoses and hydraulic ram for signs of damage and oil leaks

First 100 operational hours:
The oil should be changed.
One operational hour is equal to approx 200 raise & lower cycles.

Six monthly maintenance:

Same as weekly and monthly checks but additionally;
Remove Blocker side plates and check main shaft bearings for signs of wear.
Check that the Blocker wedge assembly is moving centrally in the frame.
Check hydraulic hoses for signs of damage or abrasion.
Check the tightness of dome headed bolts on blocker road plate and the main shaft bearing-block bolts.
Remove the Blocker inspection hatch and check the hoses and hydraulic ram for signs of damage and oil leaks

Annual maintenance:

After 3000 operational hours or every 12 months:
Same as 6 monthly maintenance but additionally:
The oil should be changed and the filter screen should be cleaned.
The nylon pivot shaft bearings should be changed.



COSSH Data sheets and handling precautions are contained in the information section

[ToC](#)

Topping up the oil:

Use a DIN 51519 Hydraulic Mineral Oil.

A list of suitable oils, can be found in the information section at the end of this manual.

Attention should be paid to the temperature ranges of the oil listed in the information section.

Care should be taken to prevent any contamination of the oil or the oil reservoir.

Oil should be added through the filler hole on top of the HPU.

Filling should be done slowly as the filler hole is fitted with a strainer which restricts the flow of oil into the reservoir.

Attention should be paid if frequent topping up is required, as this will be a sign of leakage.

Changing the oil:

Remove the oil filler cap and the screws holding the cap housing in place.

Remove the cap housing and strainer basket. The oil should be pumped out of the reservoir using a suitable hose and extractor pump.

The reservoir should be refilled with the correct grade of oil to the full mark on the sight glass.

Use a DIN 51519 Hydraulic Mineral Oil.

A list of suitable oils and COSSH data sheets and handling precautions are contained in the document section of this manual.

Check the oil level again after several operational cycles of the blocker.

Cleaning the oil filter:

Refer to *illustration hyd-002*.

Drain the oil as described previously.

Remove the 8mm hex head bolts that secure the HPU base plate to the reservoir tank.

Lift the HPU, complete with motor and base plate, high enough to be able to access the filter / strainer unit, and prop it in place.

(Replace the cork gasket if necessary).

Do not use wooden props as this risks wood particles falling into the reservoir.

Undo the filter locknut and remove the filter from the intake pipe.

Thoroughly clean the filter in paraffin / kerosene or other suitable cleaner.

Refit the cleaned and dried filter and tighten the locknut.

Lower the HPU into place, taking care not to allow any dirt to fall into the reservoir.

Refit and tighten the HPU retaining bolts. Refill with oil as described previously.

Adjusting the limit switches.

Moving the limit switch closer to, or further away from the pick-up point will adjust its sensitivity while the vertical adjustment will change the point in the cycle at which it is triggered, a combination of these two adjustments may be required.

Earlier or later triggering is achieved by moving the pick up lug, bolted to the side of the blocker wedge, up or down.

More or less sensitivity is achieved by loosening the locknuts around the body of the switch and moving it closer to or further away from the pick-up point.

Normally only very fine adjustments are required and care should be taken not to move the switch far from its original position.

Bleeding air from the hydraulic system.

Using a 17 / 19 mm spanner, crack open the hose connection at the point where the flexible hose joins the bottom of the hydraulic ram manifold.

Position an absorbent material to soak up any oil, pressurise the line by using the hand pump and observe for air / oil exiting the connection. Continue slowly pumping until the oil runs clear with no sign of air bubbles. Retighten the connection.

Repeat the procedure with the hose connection at the top of the ram manifold after manually engaging the raise solenoid.

[ToC](#)

INSTALLATION DOCUMENTS.

The following installation documents, if not included with this manual, are available on request from Avon Barrier Company Ltd.

Risk Assess RB780 -inst.

Risk assessment document covering installation process.

RB780-1-014 Rebar.

Drawing providing dimensions for fabrication of re-bar sections.

RB780-6-001 Found.

Drawing giving dimensions of blocker and concrete foundations.

RB780-6002 Stepin.

Drawing giving step instructions for blocker installation.

HPU found-large.

Drawing providing dimensions for HPU cabinet foundation.

EB-1-01. saw cut loop

Drawing providing information for installation of saw cut induction loops.

Risk Assess RB780 -maint.

Risk assessment document covering maintenance process.

NNN-2-01 Blocker electrical.

Generic wiring schematic for electrical control panel. (Site specific panel will vary).

[ToC](#)



Avon Barrier Company Ltd

DECLARATION OF CONFORMITY

E C MACHINERY DIRECTIVE 2006/42/EC

E C LOW VOLTAGE DIRECTIVE EN60204-1:1998

E C ELECTROMAGNETIC COMPATIBILITY

DIRECTIVE EN 50081-1 & EN 50082-2

U.K. PAS68 7500-80

We hereby certify that the RB780 Security Road Blocker complies with the relevant provisions of the E C Directives detailed above.

Manufactured by:

**Avon Barrier Company Ltd
Nova House
195 South Liberty Lane
Ashton Vale Trading Estate
Bristol
BS21 2TN**

Date: 1st December 2009

Name: P A Jeffrey

Position: Managing Director, Avon Barrier Company Ltd

Avon Barrier Company Ltd Nova House 191-195 South Liberty Lane Ashton Vale Trading Estate Bristol England BS3 2TN



Avon Barrier Company Ltd

WARRANTY AND LIMITATION OF LIABILITY

Avon Barrier Company Ltd. warrants that during the first 12 months following delivery, the products will be free from defect in material and workmanship.

Avon Barrier Company Ltd's sole obligation under the terms of this warranty shall be to repair (or at Avon Barrier Company Ltd's option, to replace) any defective product/part, without extra charge to the Buyer, provided that,

- (a) Buyer gives Avon Barrier Co. written notice of any such claimed defect within such period of 12 months,
- (b) The product(s), if installed, were installed by an Avon Barrier Company Ltd authorised installer,
- (c) The products have not been altered, subjected to misuse, improper maintenance, negligence or accident, or used with parts not authorised by Avon Barrier Company Ltd.

NO OTHER WARRANTY IS EXPRESSED AND NONE SHALL BE IMPLIED, INCLUDING WITHOUT THE WARRANTY OF MERCHANTABILITY OR WARRANTY OF FITNESS FOR USE.

THE FOREGOING STATES THE ENTIRE LIABILITY OF AVON BARRIER CO. LTD. WITH RESPECT TO THE PRODUCTS.

IN NO EVENT SHALL AVON BARRIER CO. LTD. BE LIABLE FOR ANY SPECIAL, INCIDENTAL OR CONSEQUENTIAL DAMAGES WHICH RESULT FROM USE BY BUYER OR ANY OTHER PARTY, OF THE PRODUCTS, AND IN NO EVENT SHALL AVON BARRIER BLOCKER CO. LTD'S LIABILITY EXCEED THE AMOUNTS PAID BY THE BUYER FOR THE PRODUCTS THEREUNDER.

DISCLAIMER

Careful consideration must be given to the selection, placement and design of a Barrier installation, and care must be taken to ensure that approaching vehicles as well as pedestrians are fully aware of the Barrier system and its operation.

Proper illumination, clearly worded signage and auxiliary safety devices, should be considered.

Avon Barrier Company Ltd. has information available on many such pieces of safety equipment not specifically listed here.

[ToC](#)

HYDRAULIC HOSE SPECIFICATION

DINAMIC 2SN MD – EN 853

Description:

- The inner tube has a smooth synthetic rubber (resistant to oils and water).
- The reinforcement has 2 high tensile steel braids.
- The hose cover has been made from synthetic rubber having a very high
- Resistance to abrasion, ozone, weather agents and flame.

Applications:

Medium high pressure lines in heavy environmental conditions, severe abrasion conditions, underground mines or strip mines.

Operating Temperature:

From -40 Celsius to 100 Celsius (Max 125 Celsius).

Hose Tolerances

I.D.		O.D.		Working Pressure		Burst Pressure		Actual Burst Pressure		Bending Radius	
DN	Inch	Mm	inch	bar	psi	bar	psi	bar	psi	mm	inch
10	3/8	19	0,748	330	4785	1320	19140	1440	20870	130	5
12	1/2	22,2	0,874	275	3990	1100	15960	1220	17680	180	7

Hydraulic hose fittings used are:

3/8 bsp 2 piece mild steel

1/2 bsp 2 piece mild steel

All fittings should be crimped by a suitably qualified engineer using the correct equipment to make sure that the required tolerance is met.

Fitting Tolerance

I.D		Outside Diameter Once Crimped	
DN	Inch	mm	inch
10	3/8	21.1	0.831
12	1/2	25.4	1

All Avon Barrier hydraulically operated equipment will be supplied with 10 metre hoses as standard.

[ToC](#)

HYDRAULIC OIL DATA SHEET

1: IDENTIFICATION OF THE SUBSTANCE / PREPARATION AND OF THE COMPANY / UNDERTAKING

Product Name: Hyspin AWS 32 6018-UK

Application: Hydraulic systems

Company: Castrol (U.K.) Limited

Address: Burmah Castrol House, Pipers Way, Swindon, Wiltshire, SN3 1RE

Telephone (24 hours): 01793 512712 Fax: 01793 491442

2: COMPOSITION / INFORMATION ON INGREDIENTS

Composition: Highly refined mineral oil and additives

Hazardous Ingredient(s) Symbol Risk Phrases Other Information %

This product contains ingredients classified as hazardous. However, they are NOT present in sufficient quantities to warrant classifying the product as hazardous

All constituents of this product are listed in EINECS (European Inventory of Existing Commercial Chemical Substances) or ELINCS (European List of Notified Chemical Substances) or are exempt.

Refer to Section 8 for Occupational Exposure Limits.

3: HAZARDS IDENTIFICATION

This product is NOT classified as hazardous

4: FIRST AID MEASURES

Eyes: Irrigate immediately with copious quantities of water for several minutes

Skin: Wash thoroughly with soap and water or suitable skin cleanser as soon as possible

Inhalation: Remove from exposure

Ingestion: Obtain medical attention. Do NOT induce vomiting.

5: FIRE FIGHTING MEASURES

Suitable Extinguishing Media: Carbon dioxide, powder, foam or water fog - Do not use water.

Special Exposure Hazards: None

Special Protective Equipment: None

6: ACCIDENTAL RELEASE MEASURES

Personal Precautions: Spilt product presents a significant slip hazard

Environmental Precautions: Prevent entry into drains, sewers and water courses

Decontamination Procedures: Soak up with inert absorbent or contain and remove by best available means

Issue No: 01 Date: 01/04/1994 Code: 6018-UK Page: 1 of 4

7: HANDLING AND STORAGE

Handling: When used in high-pressure systems, leakage may result in mist formation so presenting a hazard

To avoid the possibility of skin disorders, repeated or prolonged contact with products of this type must be avoided. It is essential to maintain a high standard of personal hygiene

Storage: No special precautions

[ToC](#)

8: EXPOSURE CONTROLS/PERSONAL PROTECTION

Occupational Exposure Limits:-

Substance 8 Hr.TWA STEL Source/Other Information

Mineral oil (see Oil mist, mineral) 5mg/m³ 10mg/m³ EH40 (OES)

Engineering Control Measures: Mechanical methods to minimise exposure must take precedence over personal protective measures

Personal Protective Equipment: Avoid skin and eye contact. Wear impervious gloves (eg PVC), in case of repeated or prolonged contact. Change contaminated clothing and clean before re-use

9: PHYSICAL AND CHEMICAL PROPERTIES

Physical State: Liquid

Colour: Amber

Odour: Mild

Boiling Point/Range (°C): Above 250

Pour Point: (°C): Below minus 30

Kinematic Viscosity @ 40°C (cSt): 32

Flash Point (closed, °C): Above 170

Autoignition (°C): Above 250

Explosive Properties (%): Not determined

Relative Density (at 20°C): Below 1.0

Water Solubility: Insoluble

Fat Solubility: Not determined

10: STABILITY AND REACTIVITY

Stability: Stable, will not polymerise

Conditions to Avoid: Temperatures (°C) above 90

Materials to Avoid: Strong oxidising agents

Hazardous Decomposition Products: None

11: TOXICOLOGICAL INFORMATION

The following toxicological assessment is based on a knowledge of the toxicity of the product's components Expected oral LD50, rat > 2g/kg

Health Effects

On Eyes: May cause transient irritation

On Skin: Unlikely to cause harm on brief or occasional contact

Issue No: 01 Date: 01/04/1994 Code: 6018-UK Page: 2 of 4

By Inhalation: Mist and vapours may cause irritation to nose and respiratory tract

By Ingestion: May cause nausea, vomiting and diarrhoea.

Chronic: Repeated and prolonged skin contact may lead to skin disorders

[ToC](#)

12: ECOLOGICAL INFORMATION

Environmental Assessment: When used and disposed of as intended, no adverse environmental effects are foreseen

Mobility: Mobile liquid. Insoluble in water. Non-volatile.

Persistence and Degradability: Inherently biodegradable

Bioaccumulative Potential: Bioaccumulative based on logP values of constituents

Ecotoxicity: Not expected to be toxic to aquatic organisms

Not expected to be inhibitory to sewage bacteria

13: DISPOSAL CONSIDERATIONS

Disposal must be in accordance with local and national legislation.

Unused Product: May be sent for reclamation

Used/Contaminated Product: Dispose of via an authorised waste contractor to a licensed site

May be incinerated

Packaging: Must be disposed of through an authorised waste contractor

May be steam cleaned and recycled

14: TRANSPORT INFORMATION

This product is NOT classified as dangerous for transport

15: REGULATORY INFORMATION

This product is NOT classified as dangerous for supply in the UK

Hazard Label Data:-

EC Directives: Waste Oil Directive, 87/101/EEC

Framework Waste Directive, 91/156/EEC

Statutory Instruments: Health & Safety at Work, etc. Act 1974

Consumer Protection Act 1987 Environmental Protection Act 1990

Codes of Practice: Waste Management. The Duty of Care

Guidance Notes:

Occupational exposure limits (EH 40)

Carcinogenicity of mineral oils (EH 58)

Skin cancer caused by oil [MS(B)5]

Save your skin! - Occupational Contact Dermatitis [MS(B)6]

Dermatitis - cautionary notice [SHW 367]

Effects of mineral oil on the skin [SHW 397]

16: OTHER INFORMATION

The data and advice given apply when the product is sold for the stated application or applications. The product is not sold as suitable for any other application. Use of the product for applications other than as stated in this sheet may give rise to risks not mentioned in this sheet.

You should not use the product other than for the stated application or applications without seeking advice from us.

Further copies of this Safety Data Sheet may be obtained from Castrol (U.K.) Limited.

Issue No: 01 Date: 01/04/1994 Code: 6018-UK

[ToC](#)

SUITABLE HYDRAULIC OILS.

BRAND (alphabetical)	Hydraulic-mineral oil HLP to DIN 51524, part 2	
	ISO - VG32	ISO - VG46
	Temperature Range	
	+10 to +60 degrees C	+20 to +70 degrees C
AGIP	AGIP OSO 32	AGIP OSO 46
ARAL	ARAL VITAM GF 32	ARAL VITAM GF 46
ASEOL	ASEOL PLUS 16-110	ASEOL PLUS
BP	BP BARTRAN HV 32	BP BARTRAN HV 46
CASTROL	CASTROL HYSPIN AWS 32	CASTROL HYSPIN AWS 46
ESSO	ESSO NUTO H 32	ESSO NUTO H 46
FUCHS	RENOLIN MR 10	RENOLIN MR
GULF	GULF HARMONY 32 AW	GULF HARMONY 46 AW
MOBIL	MOBIL D.T.E. 24	MOBIL D.T.E.
PANOLIN	PANOLIN HLP 32	PANOLIN HLP 46
SHELL	SHELL TELLUS OIL 32	SHELL TELLUS OIL 46
TEXACO	RANDO OIL HD A-32	RANDO OIL HD A-46